

## Technical Data VACUDEST XS Clearcat

52,500 – 80,000 gal industrial wastewater per year

- Highest distillate quality for oily wastewater thanks to integrated Clearcat technology
- Flexible adjustment of the treatment capacity without additional space requirement
- VACUDEST Modular-System – Customized systems
- Energy efficient due to 95 % energy recycling
- Cost efficient due highest evaporation rates
- Comfortable Vacutouch control system including internet connection
- State of the art technology stands for highest distillate quality

# VACUDEST XS Clearcat

Our VACUDEST XS Clearcat is now even more flexible. The treatment capacity can be increased within the size and without requiring any additional space. Simple and inexpensive by means of a software update.

## VACUDEST Modular-System – Features

- Included Clearcat condensation stage for complete removal of hydrocarbons
- Destcontrol to further improve distillate quality
- e-service, internet connection of Vacutouch control system



## Technical Data

Operating hours package	Annual capacity*	Reference capacity with pure water	Average capacity with wastewater*	Electrical load	Weight (empty)	Energy consumption starting from
up to 5.750 h / year	~ 52,500 gal	13 gal/h	10 gal/h	5,5 kW	1,650 lb	0.25 kWh/gal
up to 8.750 h / year	~ 80,000 gal					

\* Depending on the booked operating hours package

## Dimensions (inch)

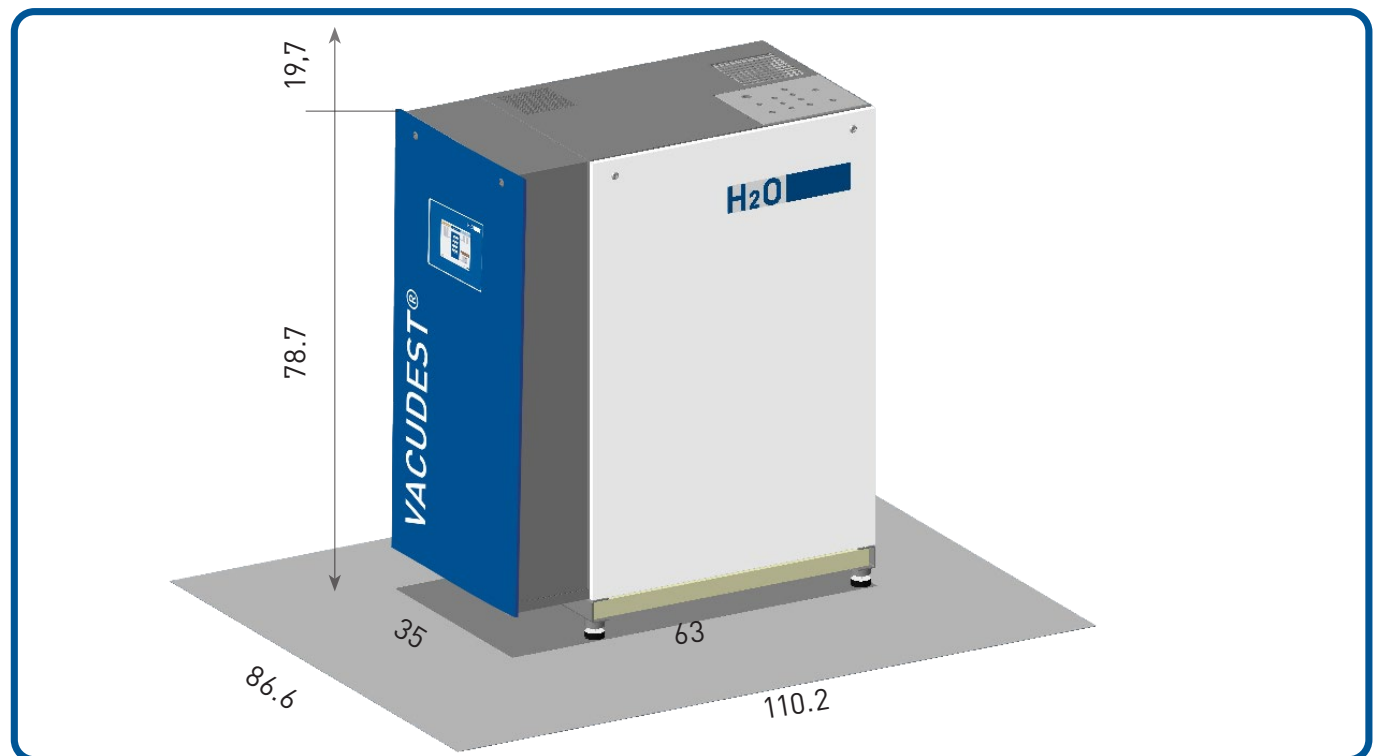

Dimensions of the VACUDEST vacuum distillation systems with optimal maintenance space

Copyright © H2O GmbH 2024 US-DB-07/2024