

Technical Data VACUDEST S

120,000 – 200,000 gal industrial wastewater per year

- Flexible adjustment of the treatment capacity without additional space requirement
- VACUDEST Modular-System – Customized systems
- Energy efficient due to 95 % energy recycling
- Cost efficient due highest evaporation rates
- Maintenance friendly design to optimize system availability
- Comfortable Vacutouch control system including internet connection
- State of the art technology stands for highest distillate quality

VACUDEST S

Our VACUDEST S is now even more flexible. The treatment capacity can be increased within the size and without requiring any additional space. Simple and inexpensive by means of a software update.

VACUDEST Modular-System – Features

- Activepowerclean self-cleaning heat exchanger, to reduce operation cost
- Clearcat condensation stage for complete removal of hydrocarbons
- Destcontrol to further improve distillate quality
- e-service, internet connection of Vacutouch control system
- Premium noise protection and much more



Technical Data

Operating hours package	Annual capacity	Reference capacity with pure water	Average capacity with wastewater	Electrical load	Weight (empty)	Energy consumption starting from*
up to 5.250 h / year	~ 120,000 gal	33 gal/h	25 gal/h	11 kW	2,800 lb	0.23 kWh/gal
up to 7.000 h / year	~ 160,000 gal					
up to 8.750 h / year	~ 200,000 gal					

* Energy consumption may vary depending on the material grade and the used equipment

Dimensions (inch)

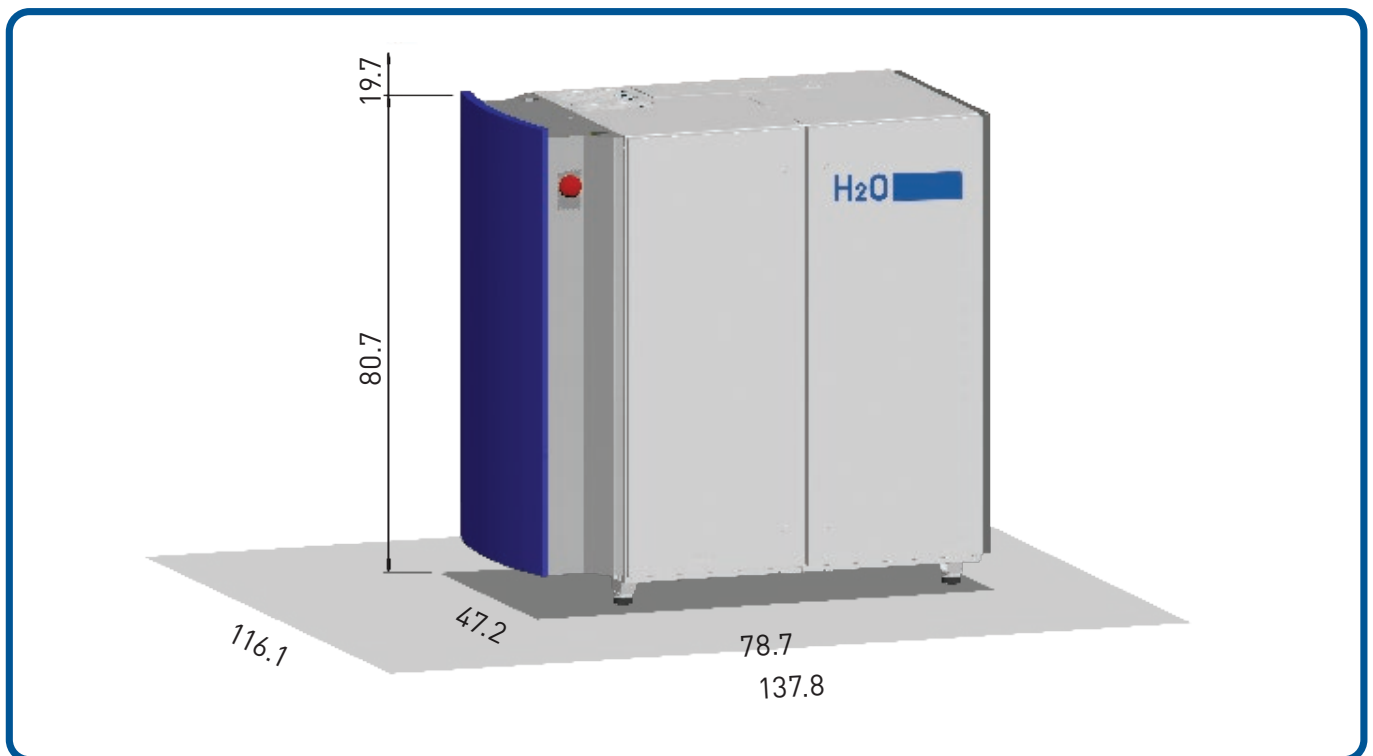

Dimensions of the VACUDEST vacuum distillation systems with optimal maintenance space

Copyright © H2O GmbH 2024 US-DB-07/2024